

W. H. ELLIOT.
Breech-loading Fire-arm.

Patented May 13, 1862.

No. 35,284.

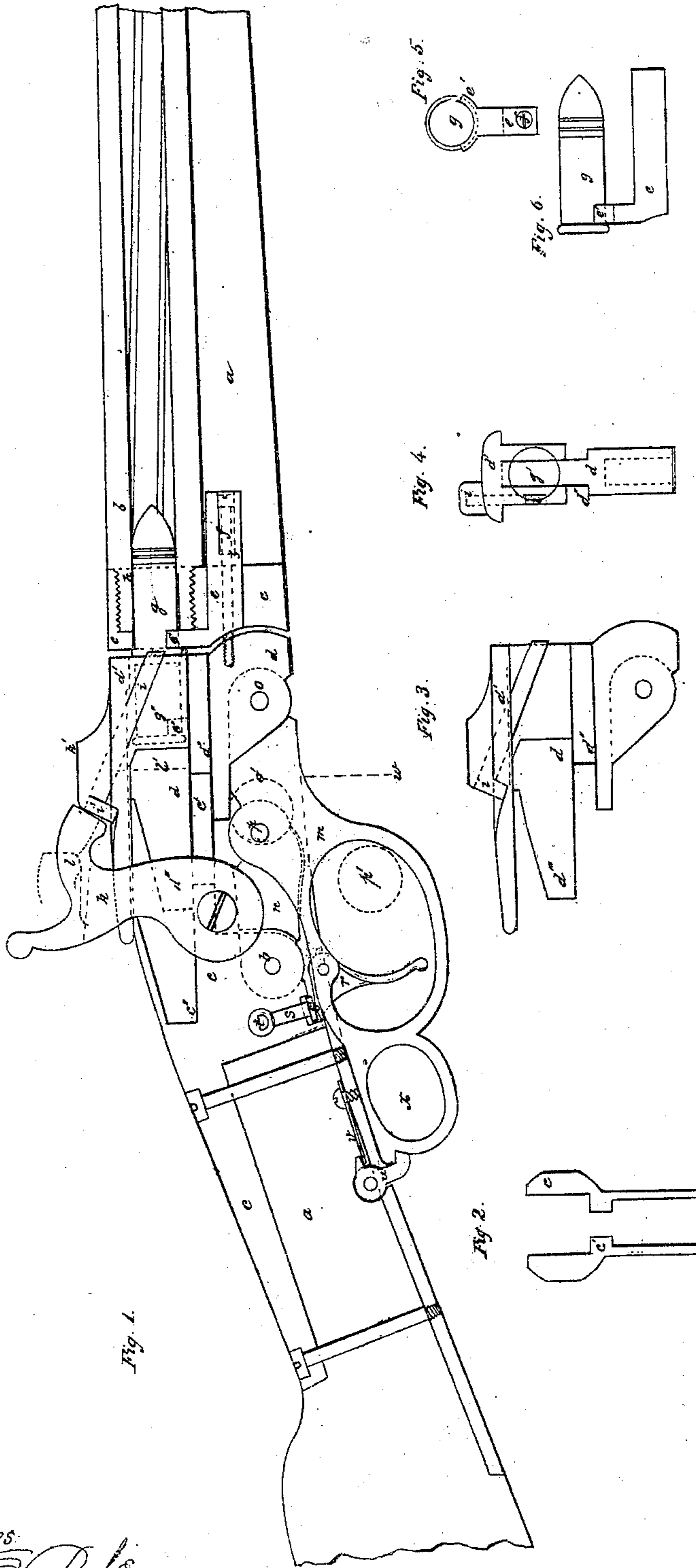

Witnesses:

Wm. H. Strong
Wm. H. Strong

Inventor:

W. H. Elliot

W. H. ELLIOT.
Breech-loading Fire-arm.

No. 35,284.

Patented May 13, 1862.

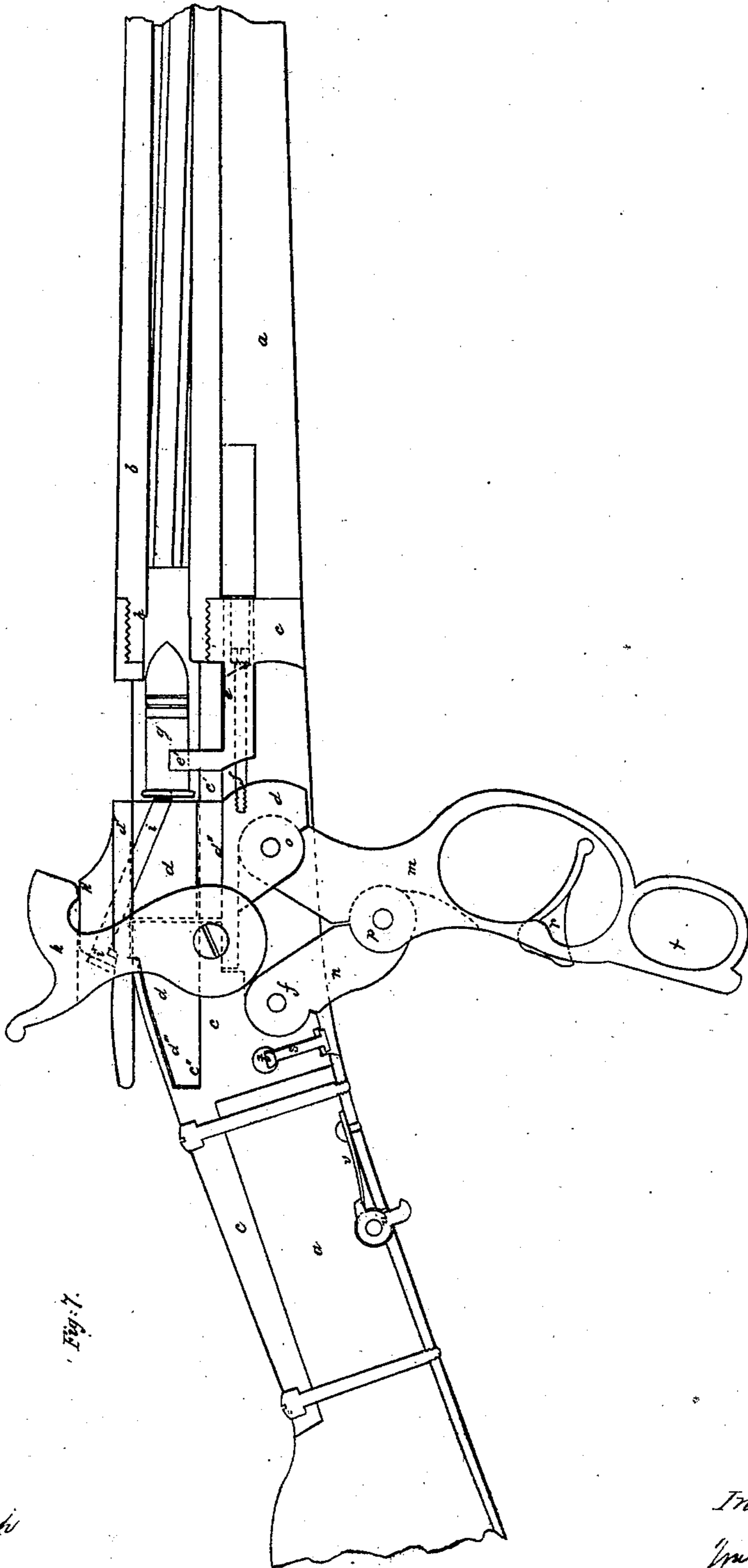

Fig. 7.

Witnesses
Benj. F. Lushbaugh
C. M. Selig

Inventor
W. H. Elliott

UNITED STATES PATENT OFFICE.

WILLIAM H. ELLIOT, OF PLATTSBURG, NEW YORK.

IMPROVEMENT IN BREECH-LOADING FIRE-ARMS.

Specification forming part of Letters Patent No. 35,284, dated May 13, 1862.

To all whom it may concern:

Be it known that I, WM. H. ELLIOT, of Plattsburg, in the county of Clinton, in the State of New York, have invented a new and Improved Breech-Loading Fire-Arm; and I do hereby declare that the following is a full, clear, and exact description thereof, reference being had to the accompanying drawings, and to the letters of reference marked thereon.

Similar letters of reference indicate the same devices in all the figures.

To enable others skilled in the arts to comprehend, make, and use my invention, I will proceed to describe its nature, construction, and operation.

The nature of my invention consists in the employment, construction, and arrangement of certain devices by which I produce a breech-loading fire-arm which is more efficient, more convenient, and more compact than any heretofore used.

Figure 1 is a representation of my improved fire-arm, showing the stock, breech-piece, and barrel in section and the moving parts in elevation. Fig. 2 is a section of the breech-piece at dotted lines *w*, Fig. 1. Fig. 3 is a side elevation of the sliding breech. Fig. 4 is an end elevation of the same. Fig. 5 is an end elevation of the cartridge and clutch for drawing the same. Fig. 6 is a side elevation of these devices. Fig. 7, Sheet 2, is the same as Fig. 1, showing the loading-chamber open for the reception of a cartridge.

a is the stock; *b*, barrel; *c*, fixed breech-piece; *c'*, projections or ribs; *c''*, surface for the tail of the sliding breech to rest upon; *d*, sliding breech; *d'*, cap of the same forming a part of it; *d''*, shoulders upon the sliding breech that rest upon the under side of the ribs *c'*; *d'''*, tail of sliding breech that rests upon surface *c''*; *e*, clutch for drawing the cartridge; *e'*, arms of the same; *f*, screw which attaches it to the sliding breech; *g*, cartridge; *g'*, its resting-place upon the sliding breech; *h*, contraction in the diameter of the chamber; *i*, firing-pin; *i'*, head of the same; *k*, hammer; *k'*, point upon the sliding breech where the nose of the hammer rests while loading; *l*, *l'*, *g''*, *e''*, *o'*, and *p'*, dotted lines showing the position occupied by the hammer-nose, sliding breech, and its cap, cartridge-shell, clutch, and the two joints of the guard-lever when the lever is depressed for the purpose of draw-

ing the cartridge-shell and opening the chamber; *m*, guard-lever; *n*, link attaching it to the breech-pin; *o*, joint attaching the sliding breech to the guard-lever; *p*, joint attaching the guard-lever to the link; *q*, joint attaching the link to the breech-piece; *r*, trigger; *s*, sear-pin; *s'*, point of contact between trigger and sear-pin; *t*, arm of sear; *u*, catch for holding the guard-lever; *v*, spring of the same; *x*, ring on guard-lever; *z*, stop for head of screw *f*.

The process of loading and firing this arm is as follows: The thumb of the right hand is placed in the ring of the guard, which is then depressed until the joint *p* is brought to *p'*, joint *o* to *o'*, front of sliding breech to *l'*, clutch *e* by means of screw *f* to *e''*, cartridge-shell to *g''*, cap *d* and hammer-nose to *l*, all the parts assuming the position more clearly represented in Fig. 7, when, upon rolling the arm upon one side, the cartridge-shell will drop out of the chamber or opening produced by drawing back the sliding breech, which may be called the "loading-chamber." A whole cartridge may then be placed in the loading-chamber, as shown in Fig. 7, and driven into the chamber of the barrel by bringing the guard-lever to the position represented at *m*, Fig. 1. As the sliding breech is carried backward, the hammer is carried back also till its nose rises above, slides over, and rests upon the top of the cap, as represented at dotted lines *l*. While in this position it ceases to act upon the sliding breech to throw it forward, but holds, by the power of the mainspring, all the parts from moving while the cartridge-shell is being thrown out and a new cartridge is placed in the loading-chamber. As the sliding breech is carried forward again for the purpose of driving the cartridge into the chamber of the barrel, the cap *d'* passes forward and the hammer falls a little and catches upon the half-cock notch upon the tumbler of the lock. By the operation of these devices the hammer is left after loading in the safest position for handling the arm, and in the most convenient position for firing it.

By reference to the drawings it may be seen that the guard-lever *m* is placed between the sliding breech *d* and link *n*, and that link *n* is placed between guard-lever *m* and fixed breech-piece *c* in the rear of that portion of the guard-lever which sustains the recoil. In my improved arm, the barrel and stock or

breech of the arm are fixed in relation to each other, the same as the common muzzle-loading arm, the sliding breech being moved by what is known as a "toggle-joint," and makes its motions within the breech-piece entirely independent of the stock or barrel; and that part of the toggle-joint which is pivoted to the sliding breech forms a portion of the lever m , and that part which is pivoted to a fixed portion of the arm is represented by link n . Thus, while my improved arm possesses all the advantages of this arrangement of the lever and link with the sliding breech, it also possesses the advantage of a barrel and stock or breech permanently fixed to each other. The hole through the clutch e for screw f is countersunk to z , so that when the sliding breech passes backward the clutch does not move till its screw-head strikes the bottom of the countersink at z , when the clutch also begins to move back, carrying with it the cartridge-shell. By this construction and arrangement of these devices, the clutch has considerably less motion than the sliding breech; still it is drawn sufficiently far back to clear the cartridge-shell from the chamber of the barrel, yet not so far but that the head of the cartridge is seen to fall in the rear of the arms of the clutch when the cartridge is placed in the loading-chamber, and as the sliding breech moves forward to close the chamber, the clutch remains stationary till these two devices and the cartridge assume the position they are to occupy in relation to each other at the moment of firing, when they move forward together, carrying the cartridge into the barrel-chamber. By this arrangement and operation of the sliding breech and clutch in relation to each other, the cartridge, though carelessly thrown into the loading-chamber, is caught and held between the clutch and sliding breech in its true position before it moves forward into the barrel-chamber.

For the purpose of obtaining greater strength and efficiency in the clutch, the arms of that device are made to form a part of the bore of the barrel-chamber, extending forward to a considerable distance, and laterally, so as to partly encompass the rear end of the cartridge.

When the loading-chamber is opened and the clutch drawn back for the purpose of receiving the cartridge, the clutch is so arranged in relation to the other parts of the breech of the arm that the cartridge is laid directly into its open arms, which so far encompass the cartridge-shell that in being drawn out the shell cannot rise sufficiently to get clear of the clutch till it is out of the chamber of the barrel, thus making the process of drawing the shell a sure one.

When the trigger is drawn back by the finger, its rear extremity strikes the lower end of pin s at s' , causing pin s to rise against the arm t of the sear and discharge the arm. The trigger is attached to and swings back and forth with the guard-lever, and, being employed with pin s , is not required to project

out upon the upper side of the guard-lever when the guard-lever is brought into the position represented in Fig. 1. The joint p passes a little by a line from o to q , so that the recoil tends to keep the lever in its position, and when the lever is so far depressed that the joints o , p , and q are in a direct line the trigger will be so far removed from the pin s that the arm cannot be discharged by it.

By reference to the drawings it may be seen that that portion of the barrel-chamber forward of h is made to fit the forward end of the cartridge-shell exactly, while the rear portion of the chamber fits the cartridge-shell loosely. This chamber is not tapering, but parallel and of two diameters. By this form all the advantages of a close-fitting chamber are obtained, as the forward and smaller portion of it is sufficient to prevent the escape of gas around the cartridge-shell, while the cartridge will pass into h without force, and the shell will fall out itself after being drawn a little distance.

The sliding breech is made in two parts. The lower part, d , as may be seen in Figs. 3 and 4, is a solid piece of metal, enough thicker at the bottom than at the top to form strong shoulders at d'' . These shoulders rest upon the under side of ribs c' with the breech-piece, and the tail of the sliding breech d''' rests upon the surface c'' on the breech-piece, the recoil of the cartridge being against the upper portion of the sliding breech, while the resistance to that recoil is in o —a point considerably below the recoil. The tendency of these forces is to cause the shoulder d'' to rise with great force against the ribs c' , while the tail of the sliding breech is thrown down upon the surface c'' with equal force. This peculiar construction of the sliding breech, with the arrangement of its bearing-surfaces and those of the breech-piece, when taken into consideration with the direction of the recoil and the points of resistance, form an important improvement in this arm, as by it I am enabled to construct in one solid piece all that part of the sliding breech which receives the recoil and has upon it the several points of resistance, while I retain the advantage of arranging the lever m and link n directly under the sliding breech, and of having the breech-piece and also the sliding breech so constructed that they cannot yield to the recoil without breaking through a great depth of solid metal.

The employment of a firing-pin, i , in connection with a breech that has a sliding motion parallel with the bore of the barrel when so arranged that its rear end projects out at the top of the sliding breech in a convenient position to be struck by a hammer which is attached to a side lock-plate and swings over the top of the arm, while its forward end projects out at the forward end of the sliding breech at a point low enough down to strike the cartridge, has a peculiar advantage, as it serves the double purpose of carrying the hammer to half-cock, and of exploding the cartridge.

Having fully described my invention, what I wish to have secured to me by Letters Patent, is—

1. So constructing and arranging the sliding breech and hammer in relation to each other that when the former is thrown back the hammer will cease to act upon it to throw it forward, but will hold it from moving by a downward pressure while the cartridge is being placed in the loading-chamber, as herein set forth.

2. The employment of a toggle-joint for moving the sliding breech when that part of said joint which forms a portion of the lever *m* is pivoted to the sliding breech, and when the other part of said joint is pivoted to a fixed

point upon the arm, substantially as herein set forth.

3. The employment of pin *s*, in combination with a trigger which is attached to and swings back and forth upon the guard-lever, and with a side lock-sear, as herein specified.

2. In arrangement and operation of the sliding breech and clutch, by which they approach each other and catch the head of the cartridge between them before driving it into the barrel-chamber, as herein specified.

WM. H. ELLIOT.

Witnesses:

E. ROCHE,
HIRAM M. STEVENS.